

Technical Requirement

- 1、 Burr<0.05,Entad。
- 2、 Surface Clean, No rust.
- 3、 Undeclared Tolerance ± 0.15 。
- 4、 Material: SPTE T0.50 #50。

| | | | | | | | | |
|--------|--|-------|--|------------|-------|------|--------|----------------------------------|
| | | Std. | | Mark Phase | Scale | Unit | Weight | STB-09 frame |
| Design | | | | S | 1:1 | mm | | |
| Check | | Appr. | | | | | | Ningbo Hexin Electronics Co.,Ltd |

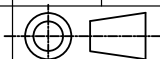

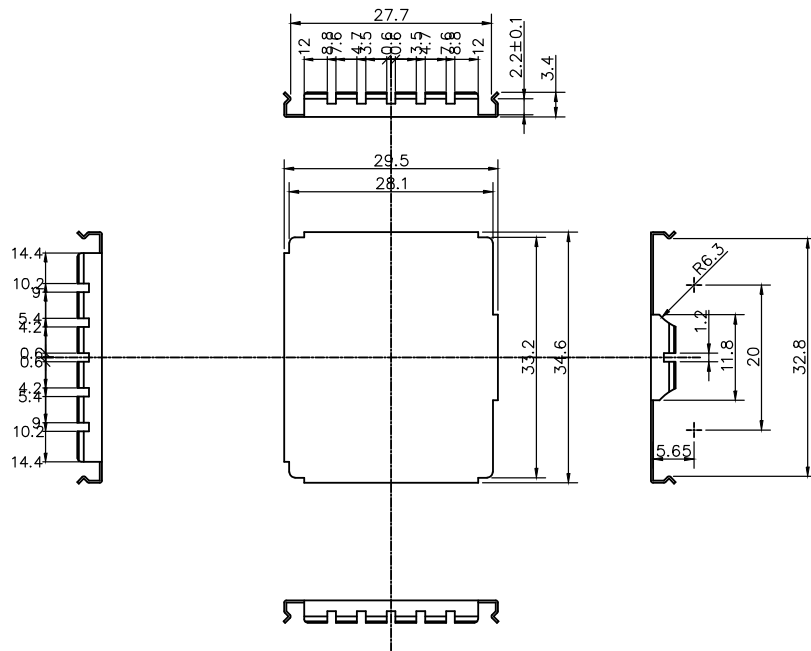

Technical Requirement

- 1、 Burr<0.05,Entad。
- 2、 Surface Clean,No rust。
- 3、 Undeclared Tolerance±0.15。
- 4、 Material: SPTE T0.30 #25。

| | | | | | | | | |
|--------|--|-------|--|------------|-------|------|--------|----------------------------------|
| | | Std. | | Mark Phase | Scale | Unit | Weight | STB-09 cover |
| Design | | | | S | 1:1 | mm | | Ningbo Hexin Electronics Co.,Ltd |
| Check | | Appr. | | | | | | |



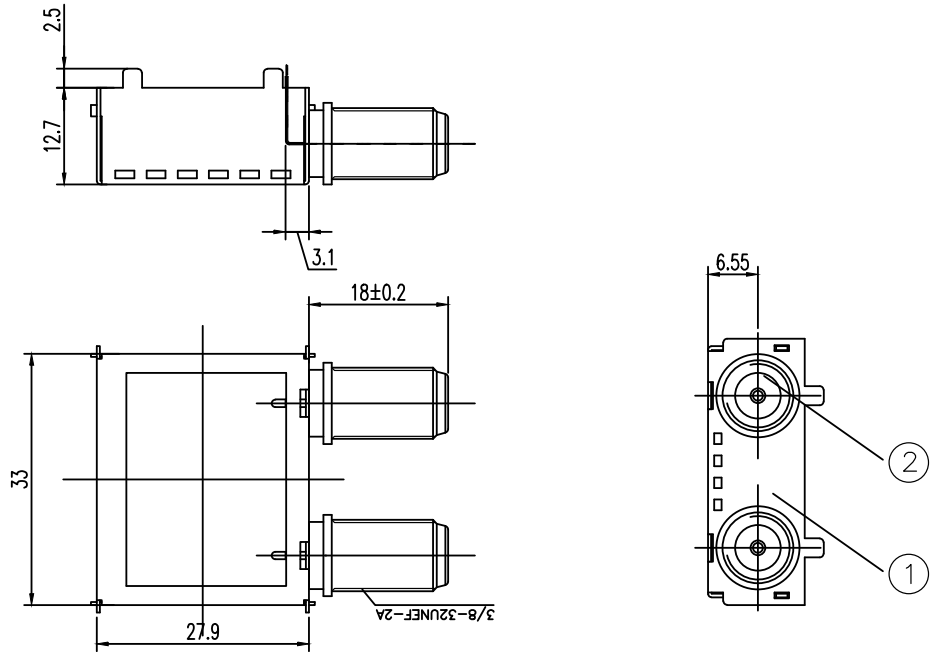

| 2 | | F CONNECTOR | | 2 | | |
|--------|----------|-------------|------------|-------|--------|----------------------------------|
| 1 | | Frame | | 1 | | |
| NO. | Part No. | Part Name | Material | Qty. | Weight | Remark |
| | | Std. | | | | STB-09 DIP Assy |
| Design | | | Mark Phase | Scale | Unit | |
| | | | S | 1:1 | mm | |
| Check | | Appr. | | | | |
| | | | | | | Ningbo Hexin Electronics Co.,Ltd |

